

# SCHROEDAHL

A subsidiary of **CIRCOR** International Inc.

## Engineering Letter Pump Protection

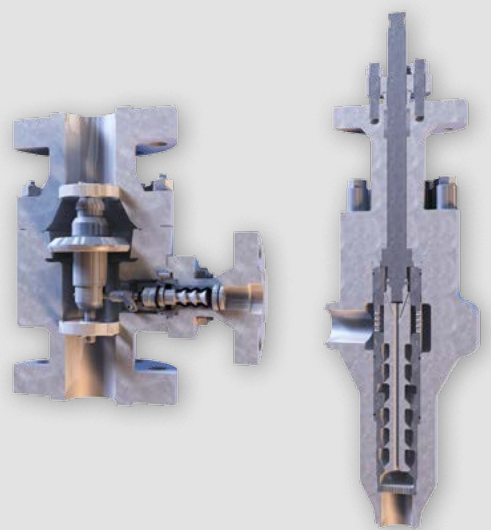



# Content

<b>1. Introduction</b> .....	1
1.1 What systems are available to ensure the minimum flow through the pump at all times? .....	2
1.1.1 Continuous Bypass System. ....	2
1.1.2 Controlled Bypass System .....	3
1.1.3 Automatic Recirculation Valves. ....	4
<b>2. The Automatic Recirculation Valve Application - Details</b> .....	5
2.1 General ARV Information .....	5
2.2 ARV Installation Recommendations .....	6
2.3 Schroedhal ARV Types .....	7
2.4 The ARV Functioning / Flow Curve .....	8
2.5 ARV Operation on Pump Curve. ....	9
2.6 ARV Application with Speed Operated Pumps .....	10
2.7 Engineering Guideline for ARVs .....	11
2.8 ARV Data Sheet for Communication and RFQ. ....	12
2.9 Signal Exchange of the Minimum Flow Control System .....	13
3.0 Schematic Arrangement for Control Valve Solution with Venturi Nozzle at Pump Discharge and Signal Controlled Pump Speed. ....	14
Notes. ....	15

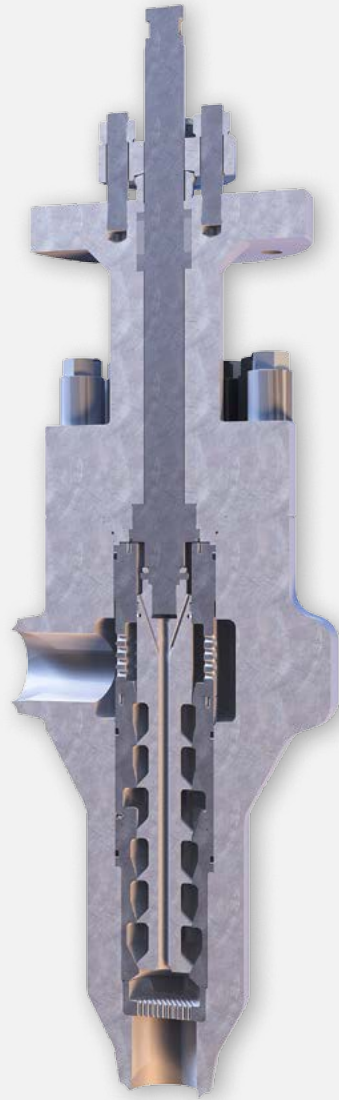
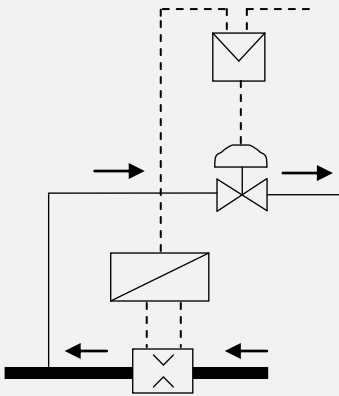
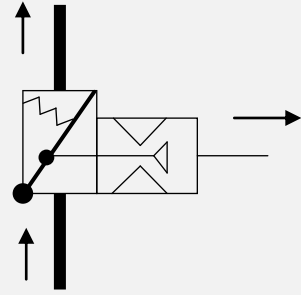
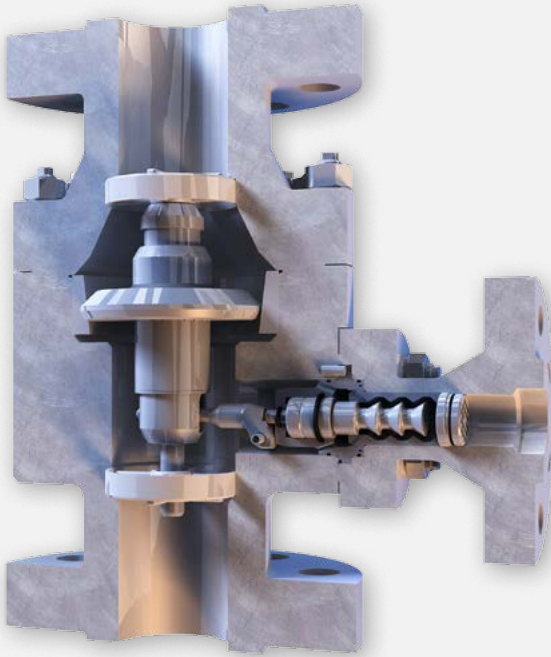

# Introduction

---

Owing to necessary cost reductions, a higher system efficiency and risk management, a reliable system to ensure a minimum flow through the pump is a prime requirement, especially for high pressure applications.

Besides protecting the pump against overheating, a well-engineered, modulating, controlled bypass system improves the stable operation of the complete system. The system itself is usually a closed loop application and therefore consists of a suction and recirculation line from and back to the tank.

Much consideration is given to the materials to be used for the valves in order to minimise corrosion and erosion under high velocity conditions or special medium applications.

## **Important advice**

In general and especially for high pressure applications, all equipment including the valves should fulfil the following requirements:

### **Reliable operation**

Production stops are very costly and it pays to accept higher initial investment rather than go for the most inexpensive solution (inexpensive can be very expensive!).

### **Ease of maintenance, good serviceability**

Although platform personnel includes highly trained technicians, the equipment should be maintenance-free or require little maintenance by the platform engineers. Time is scarce, and time costs money, especially on platforms.

### **Long life of the valve and its trim parts**

In order to prevent production loss or unnecessary doubling of control systems. Again, a cost factor!

## 1.1 What systems are available to ensure the minimum flow through the pump at all times?

### 1.1.1 Continuous Bypass System

These systems continuously bypass the flow that is required as a minimum to prevent overheating of the high pressure injection pumps. Minimum flow is usually approx. 30 % of the normal flow. The pressure at which the water is injected causes a tremendous loss of energy. Therefore, the pump to be selected should be larger in size as well as the installed capacity of the driver (130 %).

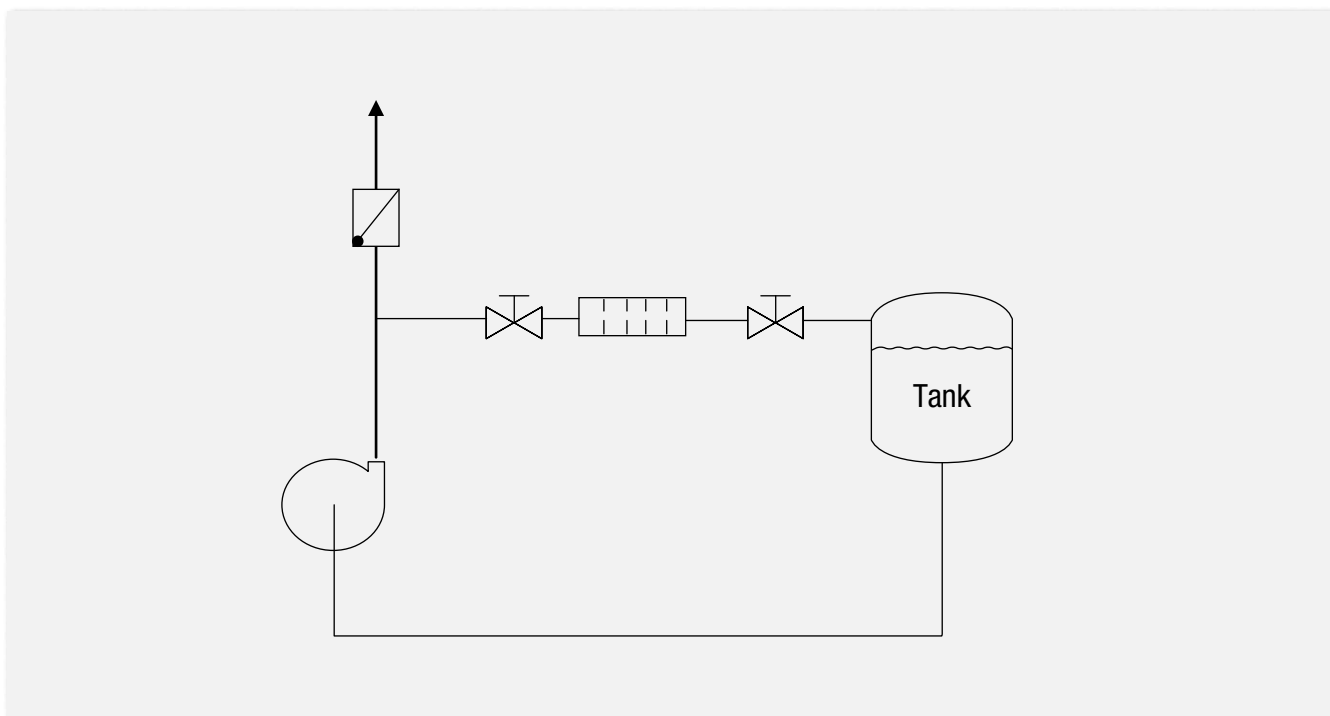

Also, a pressure reduction system has to be provided with orifice plates which are subject to cavitation and wear.

An additional check valve is needed!

#### **Pay attention to saving costs for high pressure applications!**

In a typical high pressure injection system with a normal flow of 625 m<sup>3</sup>/h (per pump), the bypass flow required is a minimum of 125 m<sup>3</sup>/h (usually 150-200 m<sup>3</sup>/h). At a pump head of 2150 m the extra power consumption of the larger pumps would be 950 kW per hour.

In continuous operation (say 300 days per year) and energy costs of 3 cents per kW/h, the extra energy costs would be roughly \$200,000.

This system is therefore very costly and it is bad engineering practice.

## 1.1.2 Controlled Bypass System

### This system consists of:

A control valve in the bypass. This control valve should be designed for high pressure reduction (e.g. from 200 bar down to 5 bar or lower). Usually, a four-stage trim (or more, depending on the make) is required and it should be equipped with an actuator to provide modulating control. It should also be available in the materials as required.

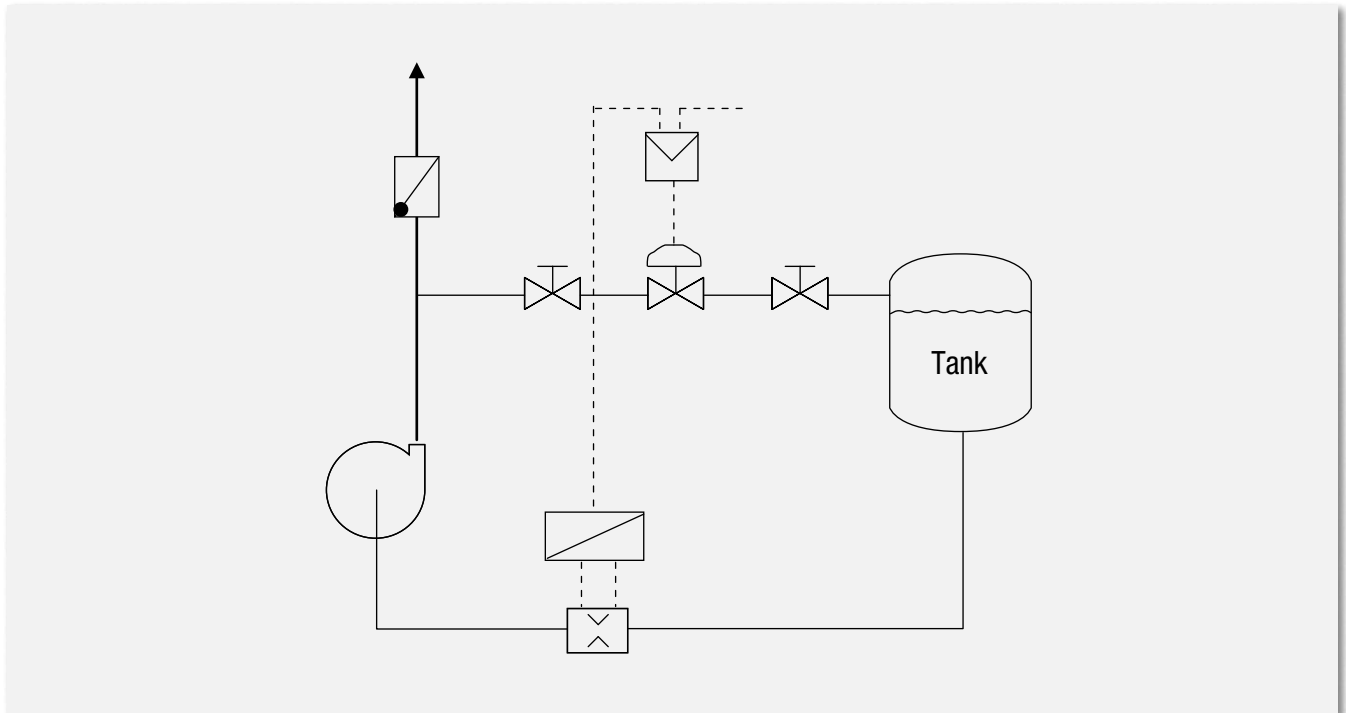

A flow sensor in the suctionline, which senses the low flow conditions to the pump. Also available in a material as specified.

A control loop which transmits the signal from the flow sensor to the control valve actuator. This requires an air or electrical supply system and requires regular maintenance and calibration.

An additional check valve is needed!

The check valve is located on the pump outlet to prevent back flow if the pump is not running. Again, the availability of the correct material for this check valve should be considered. This system has been applied (and still is) in many high pressure systems. It offers a good control of the bypass flow but has some drawbacks when compared to the system of an Automatic Recirculation Valve.

## 1.1.3 Automatic Recirculation Valves

The Automatic Recirculation Valve, manufactured and marketed by SCHROEDAHL for almost 50 years, combines the 4 functions as outlined earlier in one simple unit (see below).

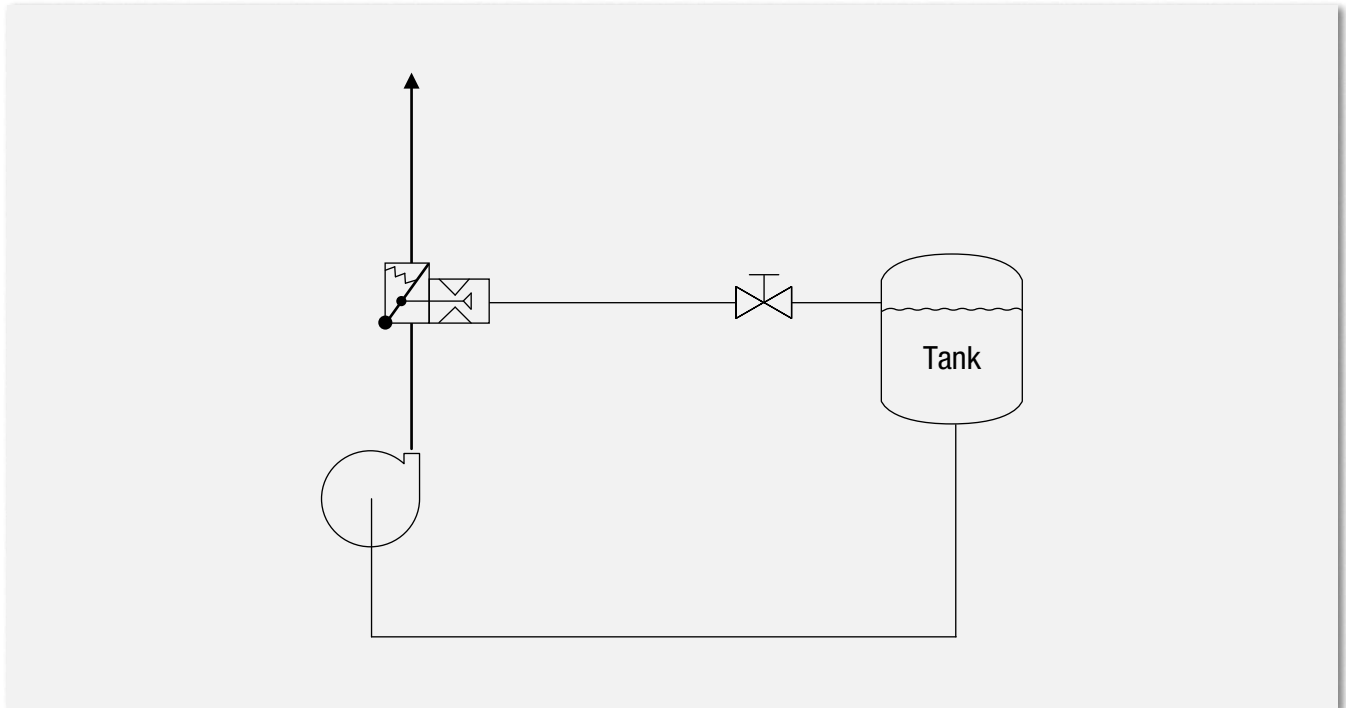

The SCHROEDAHL ARV is distinguished by:

- 1. Flow sensing and modulating function**
- 2. Check valve**
- 3. Automatic bypass end connection**
- 4. Pressure reduction of the bypass flow without cavitation**

This results in the following advantages compared to conventional systems:

One self-operated unit only, which can be mounted directly on the pump outlet. No external energy required.

Reliable, direct operation with little hysteresis. No special maintenance required; the unit is self-lubricating (pump fluid).

### Conclusion

The SCHROEDAHL valves are the most reliable valves providing minimum flow through a pump. They have many advantages over other systems and are low in initial cost (approx. 60 - 70 % of a conventional system). The valves are based on the latest technology and SCHROEDAHL has nearly 50 years of experience since the valve was invented by Mr. Odendahl of SCHROEDAHL.



# The Automatic Recirculation Valve Application – Details

## 2.1 General ARV Information

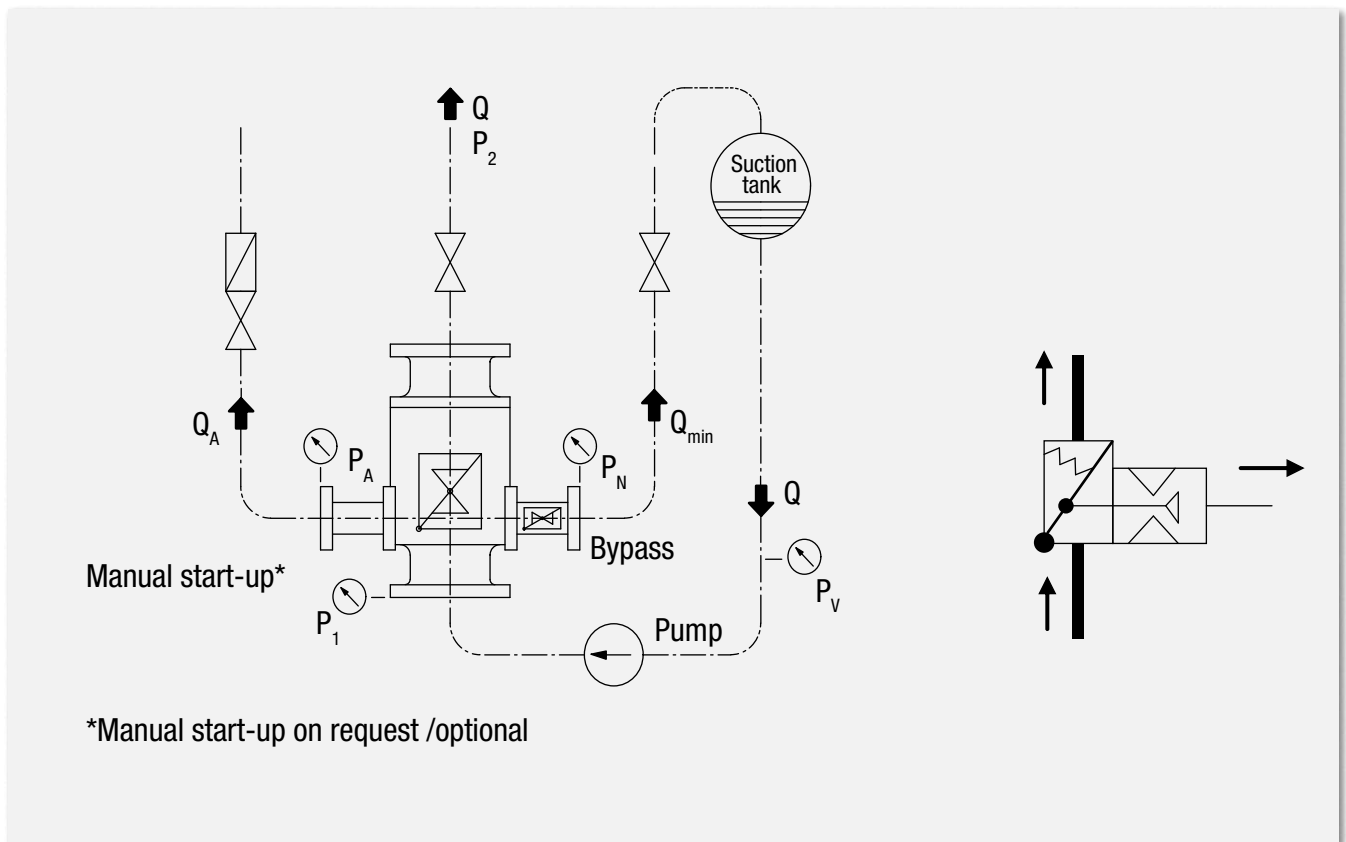

### Explanation

The Automatic Recirculation Valve (ARV) protects centrifugal pumps against overheating and cavitation problems by automatically maintaining a minimum flow when the system flow is in low load condition. The application itself is usually a closed loop application and consists of a suction and recirculation line from and to the tank. Typically the ARV is directly mounted on the pump discharge flange.

The valve system comprises a high quality check valve in the main line (see symbol above right) and a special control device for the minimum flow recirculation (the bypass control system). The general valve functioning is related to the process flow quantity – all SCHROEDAHL ARVs are flow sensitive.

Simplified function explanation: an increasing process flow will automatically reduce the bypass flow. At a certain level of process flow (the valve switch point), the recirculating bypass is closed.

## 2.1 General ARV Information

### ARV - Valve Function Description and Options

The ARV comprises a high quality check valve in the main line and a special modulating control device for the minimum flow recirculation (bypass system). The general valve functioning is related to the process flow quantity – **all SCHROEDAHL ARVs are flow sensitive**. Simplified function explanation: an increasing process flow will automatically reduce the bypass flow (modulating). At a certain level of process flow (the valve switch point), the recirculation bypass is closed.

#### Definitions:

- Q100 - (m<sup>3</sup>/h, US GPM) Rated process flow (for ARV valve design)
- QM - (m<sup>3</sup>/h, US GPM) Pump minimum flow (for ARV bypass design)
- HM - (m, feed) Pump differential pressure at minimum flow
- Pv - (bar g, psi g) Pump suction pressure
- Pn - (bar g, psi g) Bypass back pressure (at bypass flange of ARV)

### Normal or Special Operation Range Definition and Bypass Back Pressure

The pump operation data is the basic design data for the automatic pump protection valve and has therefore an influence on the valve design. The relation between the normal rated flow and the pump minimum flow is also important. Normally the pump minimum flow is not more than 30% of rated flow.

The following example pump curve should explain the ARV functioning with the minimum flow point and the rated process flow point. Please note: at the minimum flow point, the ARV bypass is completely open, and at the rated point, the full pump flow is going to the system.

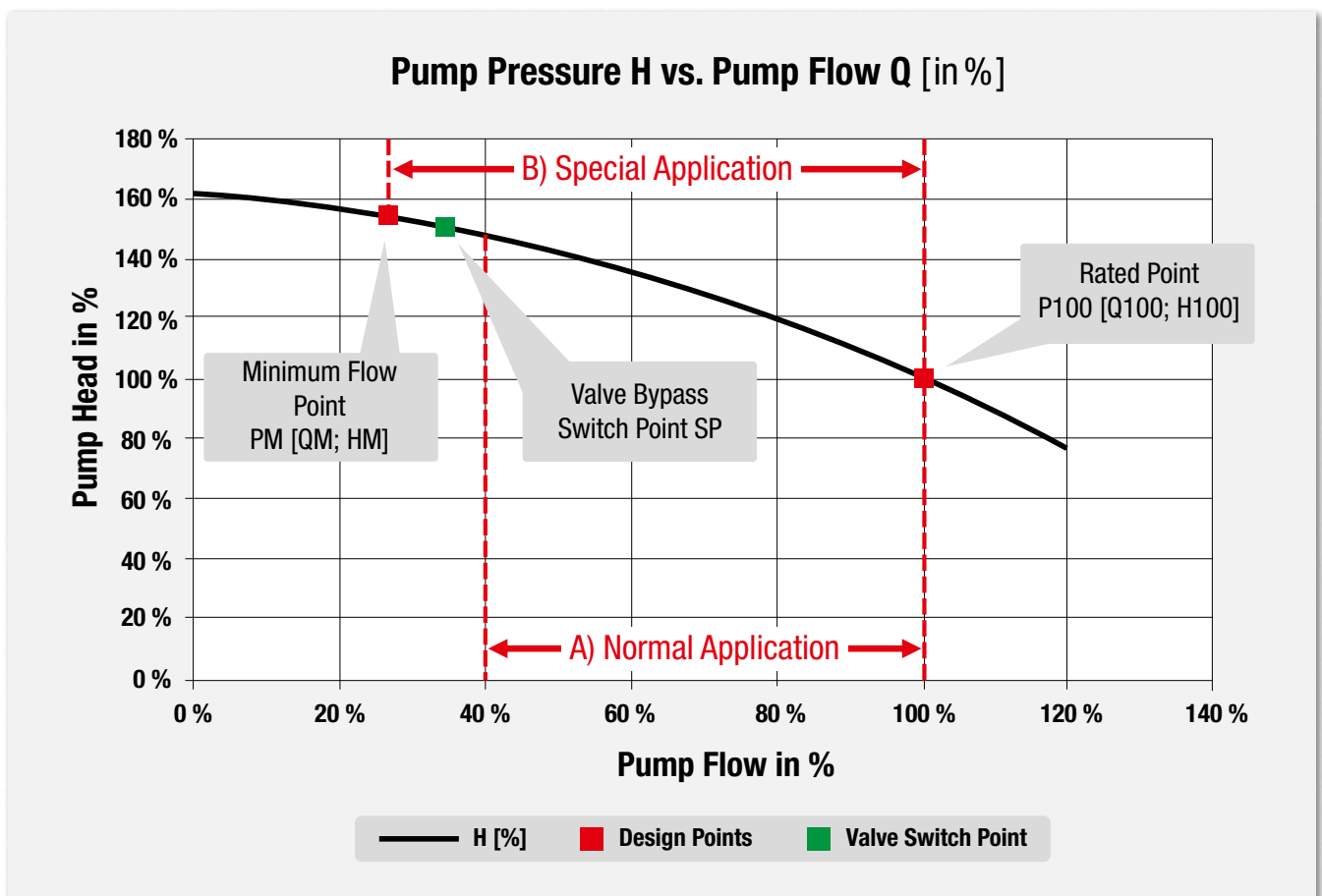

---

A valve optimum design can only be achieved when the operation data are complete. Therefore the pump protection has to be split into NORMAL and SPECIAL.

**A) Normal Application** is defined when the process flow is typically **not lower than 40%** of the rated flow (beside short start-up phases).

**B) Special Application** is defined when the system flow range is from **0% to 100%** specified. If then also the pump pressure is great than 120 bar / 1740 psi, then a Back Pressure Valve (BPV) is required, as a simple orifice cannot ensure that the **back pressure Pn is minimum 4 bar / 58 psi** higher than saturation pressure (guide value, value range is 4 to 10 bar / 58 to 145 psi).

**Note:**

A) Differentiation of Normal and Special:

Normal: An application will be classified as **Normal (A)**: when no operation range information is given.

Special: The **Special Application (B)** (>120 bar / >1740 psi) needs information about the static and dynamic bypass back pressure Pn (stat./dyn.) as well as a check about the correct bypass piping system with incorporation of the medium temperature rise at minimum flow.

B) High Pressure Applications

For applications with  $\geq 120$  bar /  $>1740$  psi differential pressure, a Back Pressure Valve (BPV) is recommended. The BPV should be installed directly before the inlet into the tank to keep the pressure in the recirculation line (Pn) minimum 4 bar / 58 psi higher (rough thermodynamic safety margin, maximum up to 10 bar / 145 psi possible and confirmed by SCHROEDAHL).

### Medium Temperature Rise

Based on thermodynamic rules due to the pressure increase and decrease, plus friction losses, the temperature of the medium rises within the pump (refer to I. J. Karassik) and ARV bypass system. With typical low efficiency of the pump at minimum flow, the temperature **rises between 10 °C and 20 °C** (for HP feed water applications). Please consider this for the recirculation system up to the inlet of the deaerator / feed water tank (flashing and choked flow collapse).

## 2.2 ARV Installation Recommendations

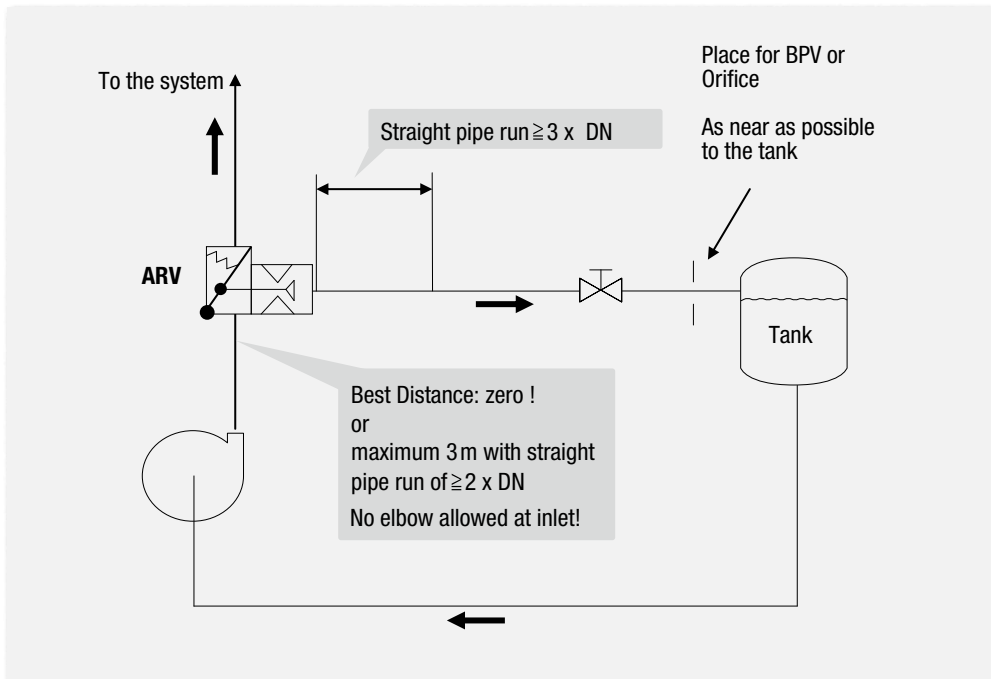

**Note:**  
Vertical installation of the ARV directly on the pump discharge is best!

### Back Pressure Valve Information

If a Back Pressure Valve (BPV) or Anti Flashing Device is requested, it should be installed as near as possible to the tank and the downstream pipe size should be preferably 1 size larger – due to flashing!

### Installation Conditions

- Vertical installation is preferred, horizontal on request.
- Preferred installation **is directly on the pump discharge flange**. Otherwise, if possible, no farther downstream than about 3 metres after the pump (depends on the application).
- The recommended **straight pipe run at the inlet** should then be at least 2 x DN (no elbows at the inlet).
- Downstream of the bypass should be in a straight pipe run of 3 x DN (no elbows).
- Standard **filter mesh size should be 0.3 to 0.5 mm** (pump suction side). For commissioning we recommend using a smaller mesh size (of 0.1 mm).
- After commissioning a valve inspection is recommended.

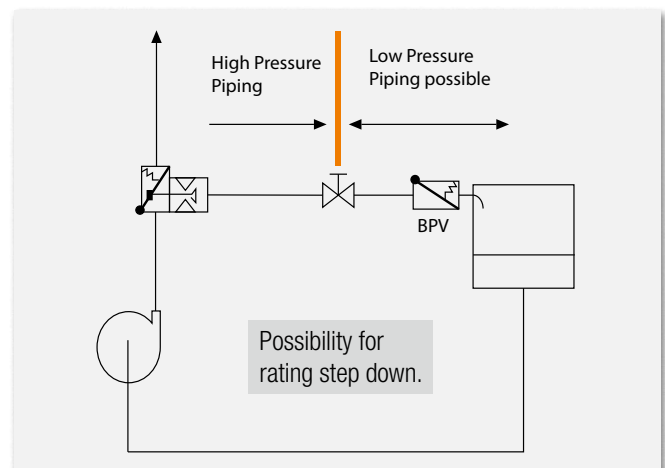
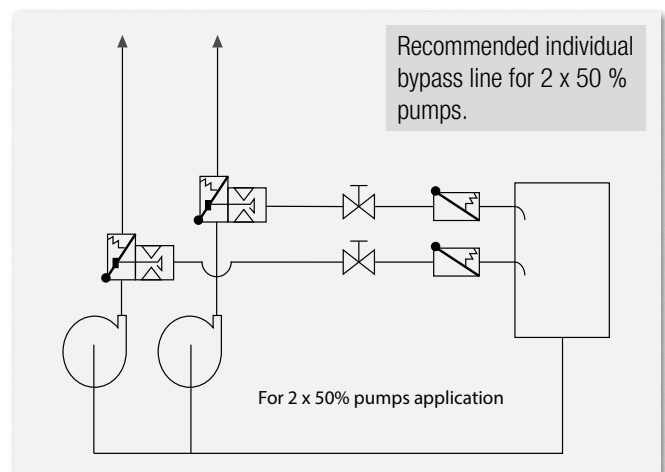

## 2.3 SCHROEDAHL ARV Types

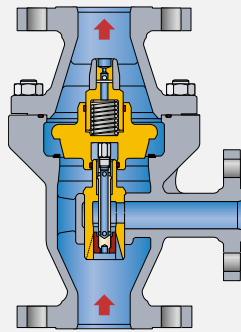

### SUL Type

- Max. Class 300 / PN 64
- Cast Body
- Economic and Efficient Design

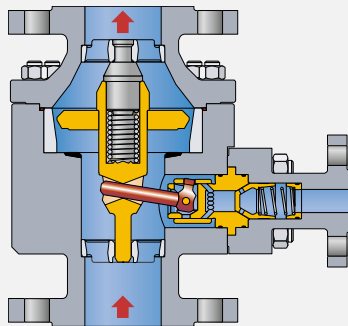

### TDL Type

- Max. Class 300 / PN 64
- Forged Body
- Check Valve in the Bypass
- Venturi Ring Design

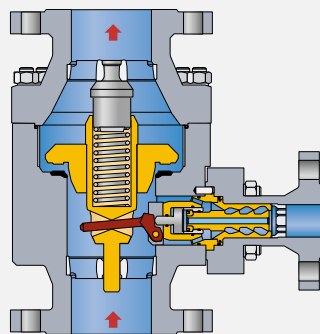

### TDM Type

- Max. Class 1500/2500 / PN 250/400
- Forged Body
- High Pressure Reduction Bypass Device (up to 5 Stages)
- Non return Function in Bypass

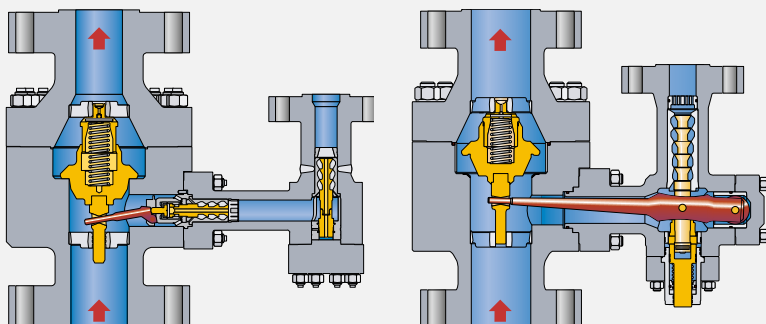

### MRK/MRM Type

- Max. Class 4500 / PN 640
- Forged Body
- High Pressure Reduction Bypass System for Pressure Reduction up to 500 bar.

## 2.4. The ARV Functioning / Flow Curve

### Modulating Bypass Function

All SCHROEDAHL valves have a modulating function; they do not have a simple ON / OFF function. Therefore, with the modulating function, they can handle load cases between zero process flow and the minimum pump operating conditions without loss of energy.

During zero process flow, the bypass is completely open. The pump is running with the specified minimum flow. When increasing the process flow, the bypass flow will decrease accordingly.

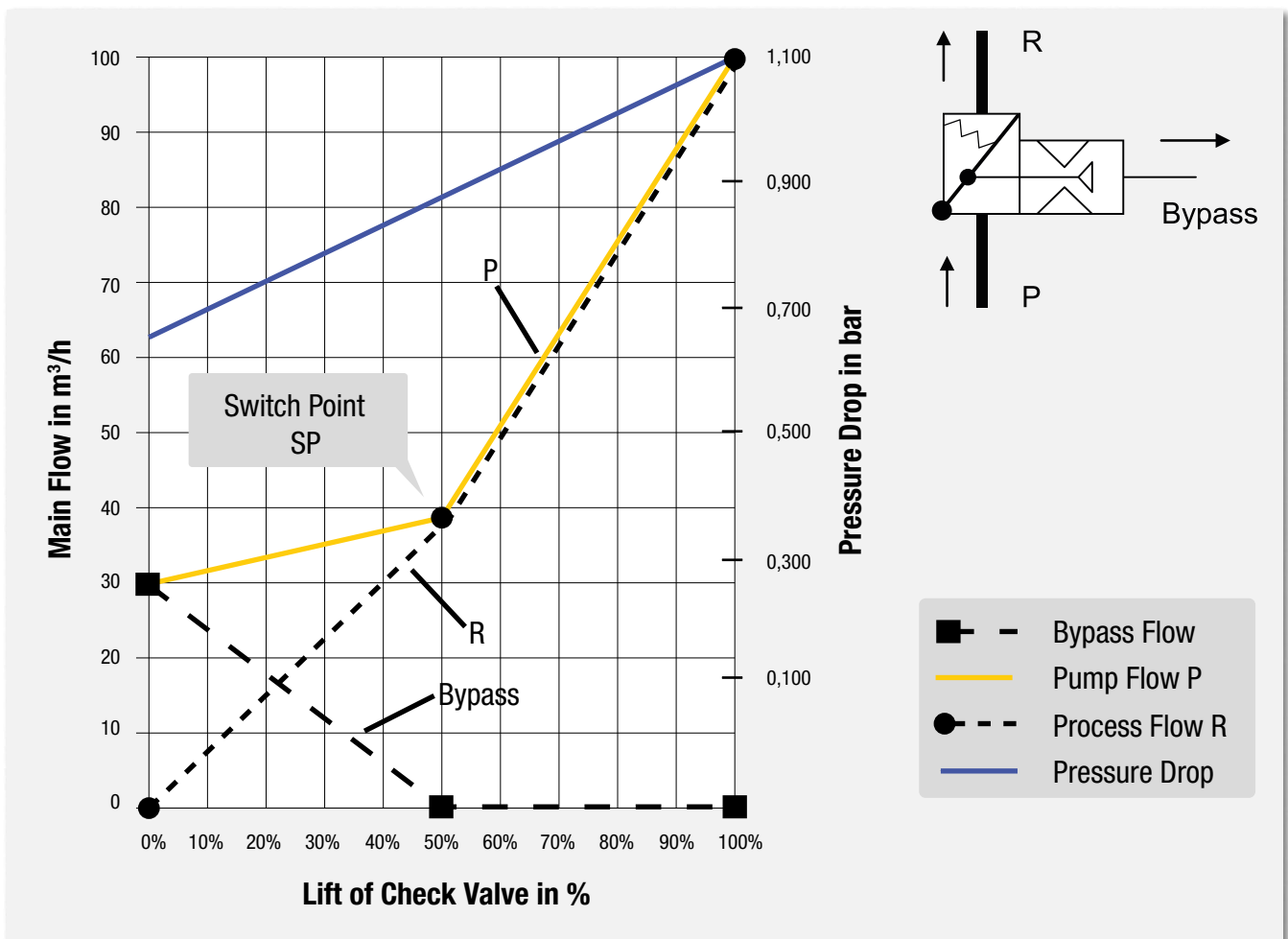

Above flow curve shows the valve behavior for the flow reduction process (shut-down event).

#### Example curve with design conditions:

Q100 % = 100 m³/h  
Qmin = 30 m³/h

#### Valve switch point (SP)

For normal operation conditions with TDM-Valves, where the bypass flow is not higher than about 30 % of the rated pump flow, the valve switch point is about 25 % higher than the specified minimum flow:

$$SP \sim Q_m \times 1.25$$

**This very low switch point is one of the advantages of SCHROEDAHL valves!**

## 2.5 ARV Operation on Pump Curve

Please refer to the following principal pump curve to understand the characteristics of an ARV according to the typical pump curve (pressure head over pump flow).

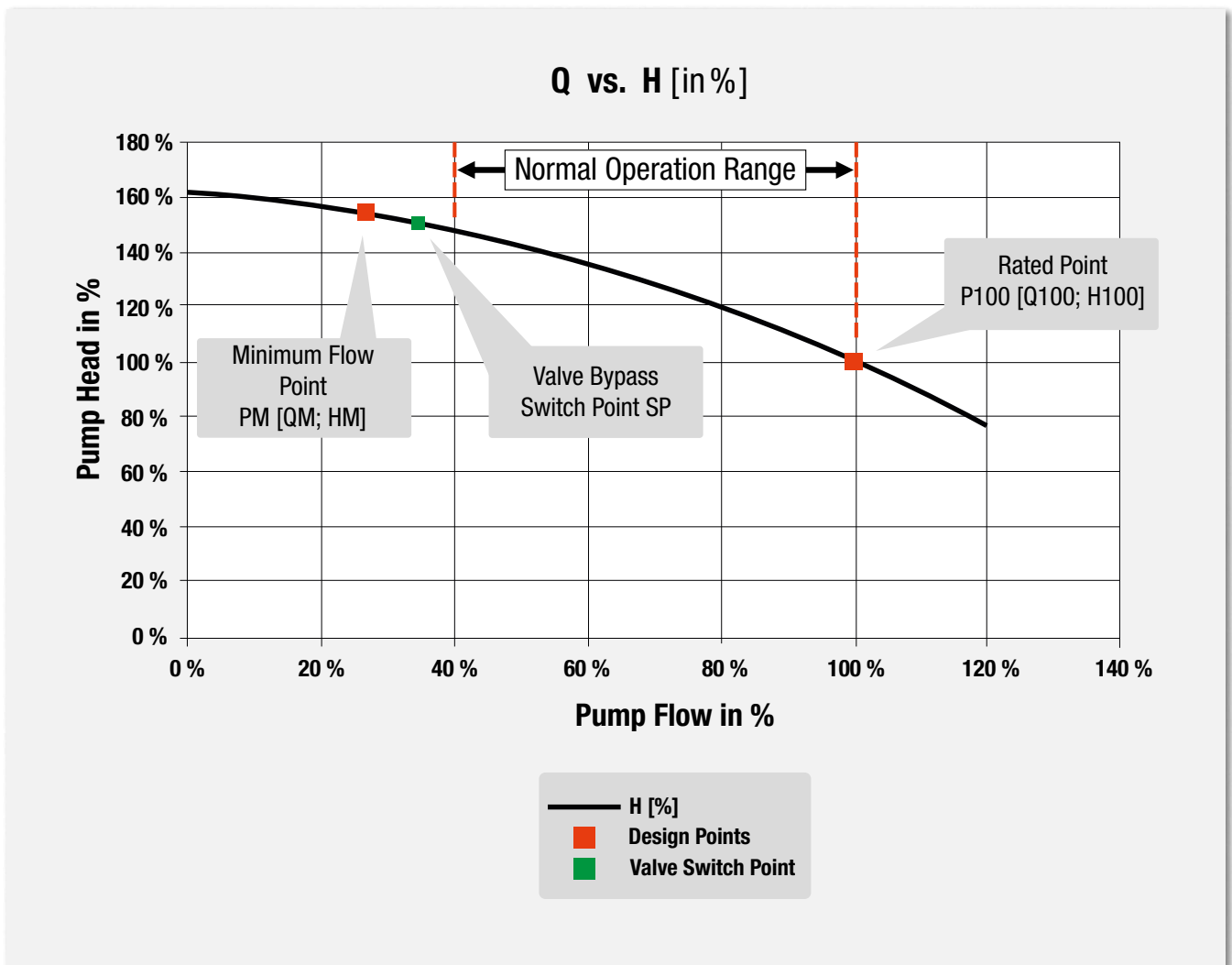

### Definition

For the curve, the normal operation point (rated point) is stated as the 100 % case with  $H = 100\%$  at  $Q = 100\%$

### Explanation

The bypass flow will decrease when the flow to the system (process flow) is increased. Therefore, the bypass flow reduces from the minimum flow point to the switch point. At the ARV switch point, the bypass flow is closed.

Usually, the system operation is between 40 % to 100 % and therefore above the valve switch point (see graph above: normal operation).

### Operation Range of Pump Protection

HP applications, which should operate from 0 % to 100 % process flow, require detailed engineering and have to be confirmed before order processing (see section 2.1).

## 2.6. ARV Application with Speed Operated Pumps

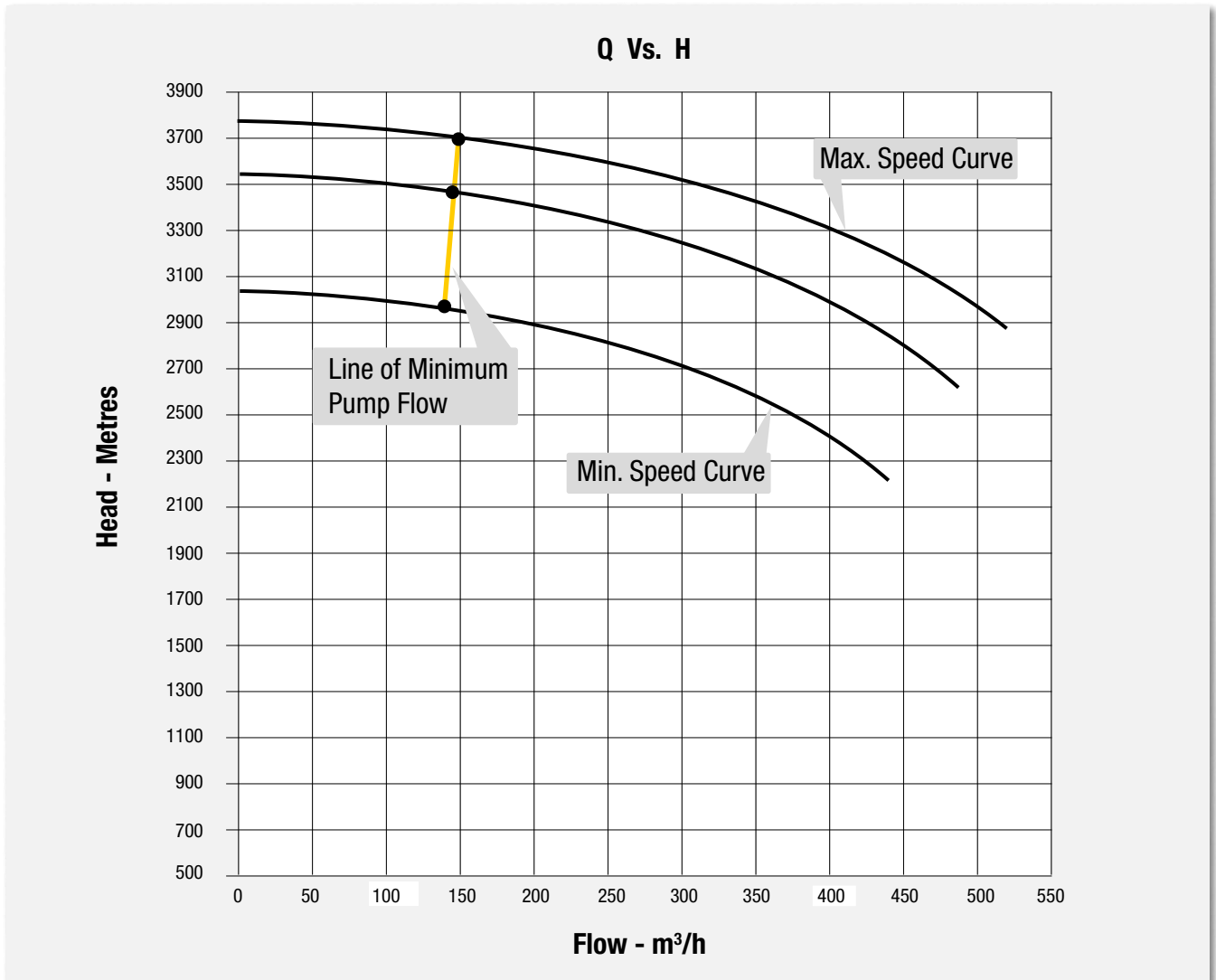

Picture: Typical Speed Operated Pump Curve

### The ARV is flow sensitive

As the ARV functioning is related only to the process flow quantity, the valve will not have a problem when it must operate at lower pump speeds / lower pump pressures. This is a very big advantage of the ARV solution compared with a Control Valve system.

### Valve calculation

For the valve design we calculate / incorporate all given speeds with its minimum flow points and will ensure that all different operation points are covered (worst case scenario). The ARV pump protection will have a large and sufficient operational range.

### The ARV is able to handle speed operated pumps – easily!

#### Note:

Please also inform us about the load data if a booster pump with constant speed is installed.



## 2.7 Engineering Guideline for ARV's

---

### Materials

- Standard temperature range from -196 °C to +260 °C (LP up to +400°C)
- Standard sealing material is EPDM, NBR, FKM, FFKM
- SUL valves are available in CS and SS housing material only (cast body)
- TD, MRM and MRK valves: CS, SS, LT, Duplex, Super Duplex  
Special materials on request!

### Differential Pressure at Rated Flow

The differential pressure at rated flow (based on normal medium velocities of 4 to 5 m/s):

- **SUL approx. 0.3 bar**
- **TDL approx. 0.4 bar**
- **TDM approx. 1.0 bar** (approximate figures, depending on load conditions)

### Installation Conditions

- **Preferred vertical**, horizontal on request.
- Preferred **installation is directly on pump discharge flange**, otherwise, if possible, no farther downstream than about 3 metres after the pump (depends on application).
- Standard **filter mesh size should be 0.3 to 0.5 mm** (pump suction side). For commissioning we recommend a smaller filter size of 0.1 mm.

### Examinations, Tests and Certificates

- Standard certificates acc. EN 10204 / 3.1 and 97/23/EG (PED for CE-Marking for Europe).
- Leakage:  
Main Check Valve: FCI 70.2 Class IV (all valves)
- Bypass: FCI 70.2 Class IV (only TDM / MRM valves); TDL and SUL are not tight closing (LP application).
- Witnessed inspection by customer or third party inspection.
- Non-destructive examinations on request for TD, MRM and MRK series (not for SUL type).
- Bypass Kv Value test certificate, on request.
- Flow curve for TDM, MRM and MRK series, on request.

## 2.8 ARV Data Sheet for Communication and RFQ

### Automatic Recirculation Valve RFQ Datasheet

Client:	<input type="text"/>	TAG No.:	<input type="text"/>
Customer Ref.:	<input type="text"/>	Qty.:	<input type="text"/>
Project:	<input type="text"/>		
System Description:	<input type="text"/>		
Valve Inlet	DN <input type="text"/>	PN <input type="text"/>	Flange Standard (DIN EN/ ASME;...): <input type="text"/>
Valve Outlet	DN <input type="text"/>		Installation: (vertical = standard) <input type="text"/>
Bypass	DN <input type="text"/>		Painting: (Stand./ Spec.) <input type="text"/>
Manual Start-Up (if req.)	DN <input type="text"/>		

Certificates: (e.g. EN 10204 / 3.1,...)

Specification/ Specials/ NDT Requirements:

Carbon Steel, Stainless Steel, Duplex, others:

Housing Material:

Medium:

Operating Temperature:  °C

S.G.:  in kg/dm<sup>3</sup>, t/m<sup>3</sup>

Design Temperature:  °C

Design Pressure:  bar g

$Q_{100} =$   m<sup>3</sup>/h     $H_{100} =$   m

Suction Pressure  $p_v$ :  bar g

$Q_{max} =$   m<sup>3</sup>/h     $H_0 =$   m

Back Pressure Bypass  $p_N$ :  bar g

$Q_M =$   m<sup>3</sup>/h     $H_M =$   m

Back Pressure Start-up  $p_A$ :  bar g

$Q_A =$   m<sup>3</sup>/h     $H_A =$   m

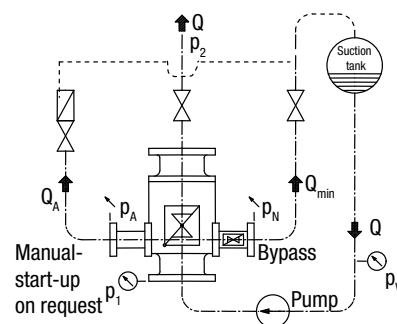
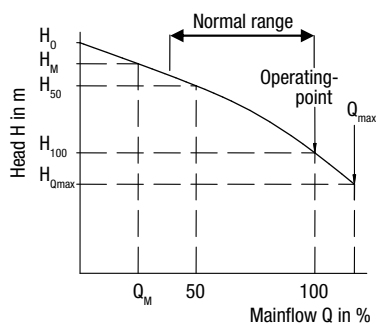

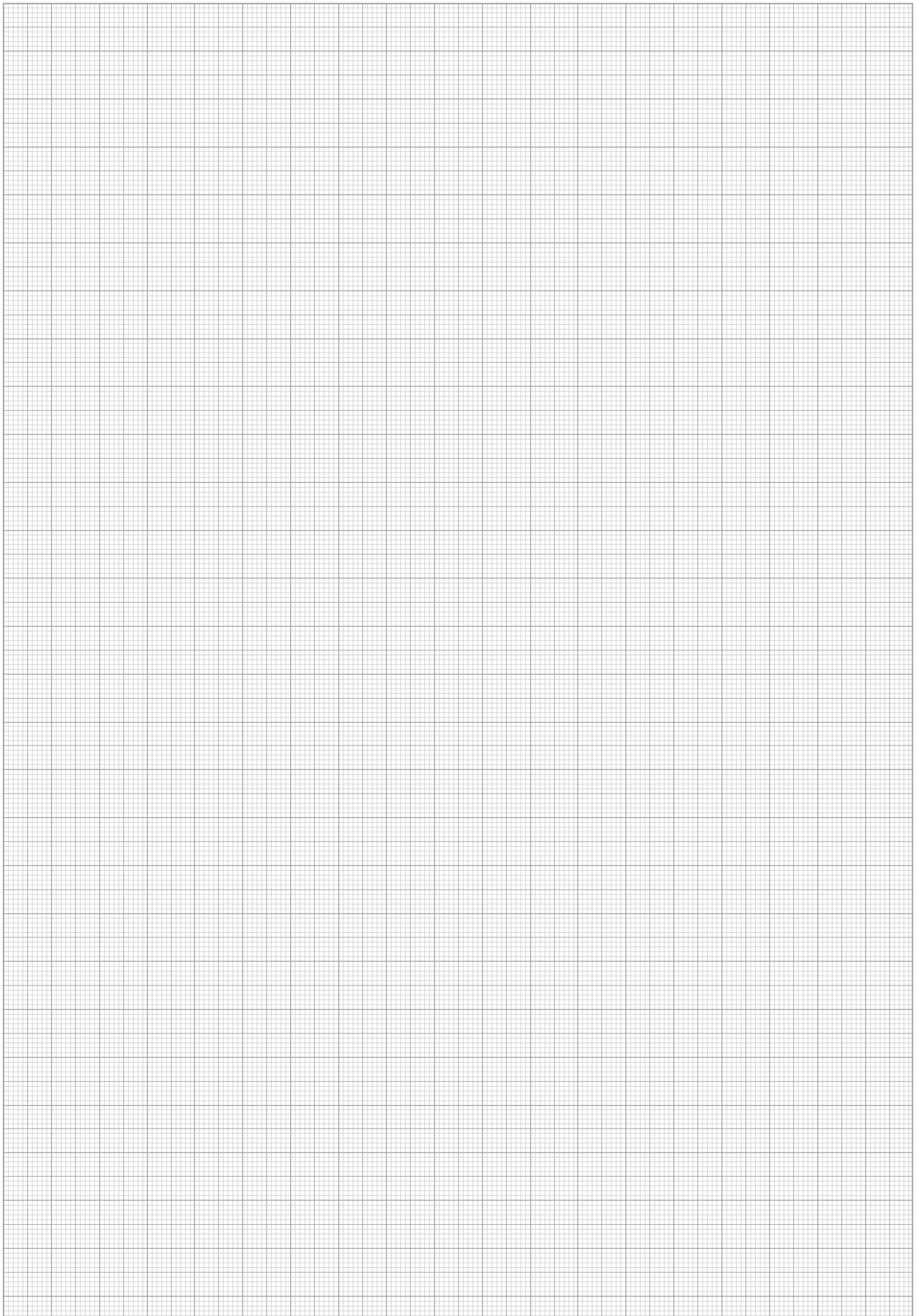



# SCHROEDAHL

A subsidiary of  CIRCOR International Inc.

## **SCHROEDAHL GmbH**

Alte Schönenbacher Str. 4  
51580 Reichshof-Mittelagger  
GERMANY

Phone +49 2265 9927-0  
Fax +49 2265 9927-927

[www.schroedahl.com](http://www.schroedahl.com)  
[schroedahl@circor.com](mailto:schroedahl@circor.com)